

HASSELBLAD HCD 4/28

The HCD 28mm lens has been designed to be compact and to deliver optimal performance when used with the 48x36mm sensor of the Hasselblad H3D. Image quality from the Hasselblad H3D is refined with integral use of Digital APO Correction which perfects the raw image by digitally removing any color aberration and distortion. The resulting raw images have perfect pixel definition optimal for image rendering.

GENERAL LENS DATA

Focal length	28.9 mm
Aperture range	4 - 32
Angle of view diag/hor/vert	95°/83°/66°
Length/diameter	102 mm/100 mm
Weight (incl. covers and lens shade)	850 g
Filter diameter	95 mm

CLOSE FOCUS RANGE DATA

Minimum distance object to film	0.35 m
Maximum image scale	1:7.3
Corresponding area of coverage	36 x 27 cm
Corresponding exposure reduction	0 f-stop

COMPATIBILITY

- The HCD 4/28 mm is designed for use on the Hasselblad H3D and the H2F camera.
- The HCD 4/28 mm lens is designed solely for digital use. This means that the lens is designed for a format of 37x49 mm and does not cover the film format (41.5x56mm). The function is therefor disabled when using a film magazine.
- The HCD 4/28 mm lens is not compatible with the converter 1.7x.



LENS DESIGN

12 elements in 9 groups

FOCUS TYPE

Rear focusing

ENTRANCE PUPIL POSITION

134 mm in front of the sensor plane
(at infinite focus setting)

The entrance pupil position is the correct position of the axis of rotation when making a panorama image by combining individual images of a scene.

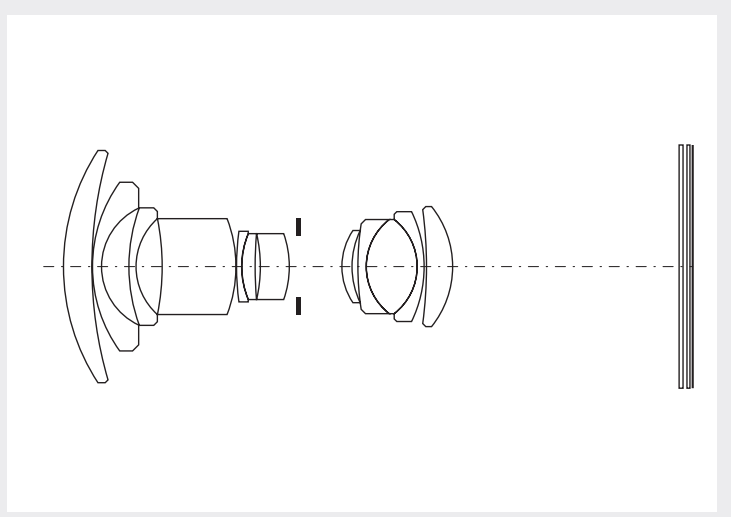

HASSELBLAD HCD 4/28

MTF

Modulation Transfer as a function of image height at infinite focus setting.

Sagittal slit orientation drawn with continuous line and tangential with dashed. White light. Spatial frequencies 10, 20 and 40 lp/mm

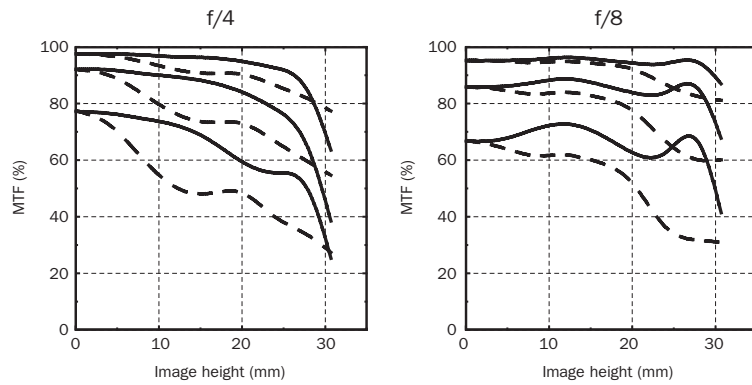

RELATIVE ILLUMINATION

Infinity setting

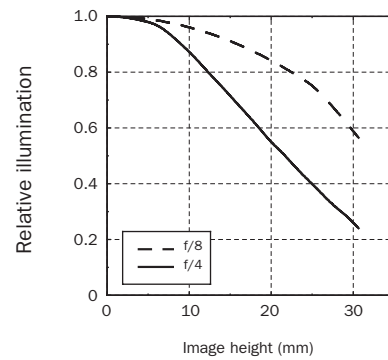

DISTORTION

Infinity setting

